



EPT20-30RTS EPT20-35RTS Electric Pallet Truck 3.0/3.5t

Pallet Truck with Higher Speed and Greater Capacity;
Provides an ideal choice for Super-tough Working Conditions;
Maximum Capacity Reaches 3.5T and Driving Speed up to 12KM/H;
Dual Pallet Forks Option Doubles Material Handling Efficiency.

EP EQUIPMENT CO.,LTD
www.ep-ep.com



FEATURE



Performance

- The innovative AC system offers strong power, accurate control, excellent performance.
- High strength vertical gearbox, longer working life.
- Low-noise but durable hydraulic unit, good quality cylinder as well as hose ensure the high reliability of hydraulic system.
- AMP connector and durable electric wires greatly reduce malfunctions of components.
- Super high intensity frame design supports high speed, high capacity and long distance applications.
- Adjustable long push rod ensures the stability and lifespan of the truck.

Safety

- Moving parts are far from operator to avoid accidents.
- Operator can freely switch between high speed/low speed switch, by which safety and reliability are greatly enhanced.
- Dual protection arm can assure the operator to be protected in any standing position.
- Emergency reverse belly button protects operator from getting hurt.
- Emergency disconnecter will cut off power source to avoid accident when truck goes out of control.
- Large pedal allows operator to stand fully inside and well-protected.
- Anti-rolling back brake keeps the truck from skidding down when truck is out of control or travelling on ramp.
- Dual-monitoring power steering, the top safety design (electric steering).

Operation

- With the new design of ergonomical tiller head, all buttons can be reached conveniently & comfortably.
- Thanks to the entry roller design, this truck enters and exits pallets easily.
- With the design of ergonomical tiller and buttons, the truck can be operated safely and comfortably under various applications with excellent working view.
- High speed wheel are chosen as standard configuration.
- Can be functional as low level order picker with coast control option.
- Side&top open battery compartment allows various battery option, convenient for replacement and maintenance.
- Electric power steering, smooth & comfortable (EPS).

Maintenance

- AC traction motor, maintenance free.
- Hour meter and battery indicator remind operator of battery charging.
- Easily remove the back cover by only losing four bolts; Access to all key components for inspection, maintenance and replacement.
- Vertical motor makes the inspection & service much more convenient.
- Control system allows easy trouble-shooting.
- Low voltage lift cut off design protects the battery.



Electric Pallet Truck 3.0/3.5t EPT20-30RTS/EPT20-35RTS

Distinguishing mark					
1.1	Manufacturer			EP	EP
1.2	Model designation			EPT20-30RTS	EPT20-35RTS
1.3	Drive unit			Electrics	Electrics
1.4	Operator type			standing	standing
1.5	rated capacity	Q	kg	3000	3500
1.6	Load center distance	c	mm	600	600
1.8	Load distance	x	mm	1042	1042
1.9	Wheelbase	y	mm	1722	1722
Weight					
2.1	Service weight (include battery)		kg	850	920
2.2	Axle loading, laden driving side/loading side		kg	1110/2740	1260/3160
2.3	Axle loading, unladen driving side/loading side		kg	630/220	690/230
Types,Chassis					
3.1	Tyre type driving wheels/loading wheels			polyurethane/ polyurethane	polyurethane/ polyurethane
3.2	Tyre size, driving wheels (diameter×width)		mm	Φ254x95	Φ254x95
3.3	Tyre size, loading wheels (diameter×width)		mm	Φ82.5x165	Φ82.5x165
3.4	Tyre size, caster wheels (diameter×width)		mm	Φ100x63.5	Φ100x63.5
3.5	Wheels, number driving, caster/loading (x=drive wheels)		mm	1x+2/ 2	1x+ 2/ 2
3.6	Track width, front,driving side	b ₁₀	mm	668	668
3.7	Track width,rear,loading side	b ₁₁	mm	456	456
Dimensions					
4.4	Lift height	h ₃	mm	140	140
4.9	Height drawbar in driving position min./max.	h ₁₄	mm	970/1602	970/1602
4.15	Lowered height	h ₁₃	mm	82.5	82.5
4.19	Overall length	l ₁	mm	2325	2325
4.20	Length to face of forks	l ₂	mm	1140	1140
4.21	Overall width	b ₁ / b ₂	mm	915	915
4.22	Fork dimensions	s/ e/ l	mm	56/230/1190	56/230/1190
4.25	Outside width of the forks	b ₅	mm	686	686
4.32	Ground clearance, center of wheelbase	m ₂	mm	26.5	26.5
4.34.1	Aisle width for pallets 1000 × 1200 crossways	Ast	mm	2984	2984
4.34.2	Aisle width for pallets 800 × 1200 lengthways	Ast	mm	2812	2812
4.35	Turning radius	Wa	mm	2190	2190
Performance data					
5.1	Travel speed, laden/ unladen	km/ h	km/h	10.5/12	10.5/12
5.2	Lifting speed, laden/ unladen		m/ s	0.03/0.033	0.028/0.033
5.3	Lowering speed, laden/ unladen		m/ s	0.040/0.038	0.040/0.038
5.8	Max. gradeability, laden/unladen		%	8/16	6/16
5.10	Service brake type			Electromagnetic	Electromagnetic
Electric-engine					
6.1	Drive motor rating S2 60 min		kW	4	4
6.2	Lift motor rating at S3 15%		kW	2.2	2.2
6.3	The maximum allowed size battery		mm	812x330xopen	812x330xopen
6.4	Battery voltage/nominal capacity K5		V/Ah	24/280	24/360
6.5	Battery weight		kg	250	320
Addition data					
8.1	Type of drive control			AC	AC
10.5	Steering type			Mechanical/ Electronic	Mechanical/ Electronic
10.7	Sound pressure level at the driver's ear		dB(A)	74	74

If there are improvements of technical parameters or configurations, no further notice will be given.
The diagram shown may contain non-standard configurations.

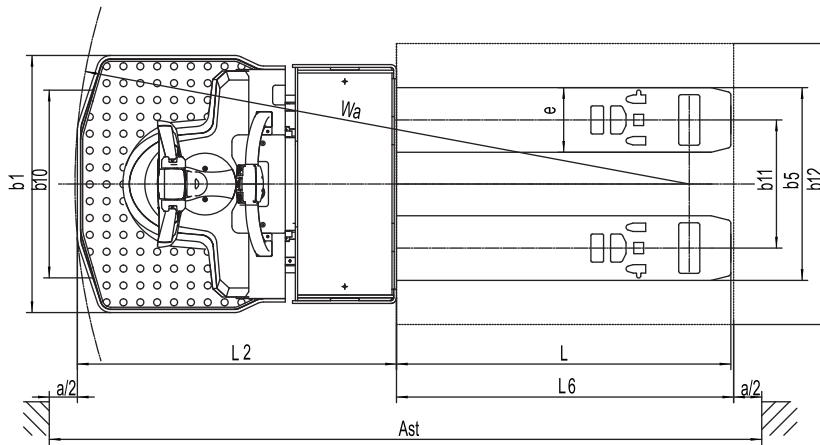
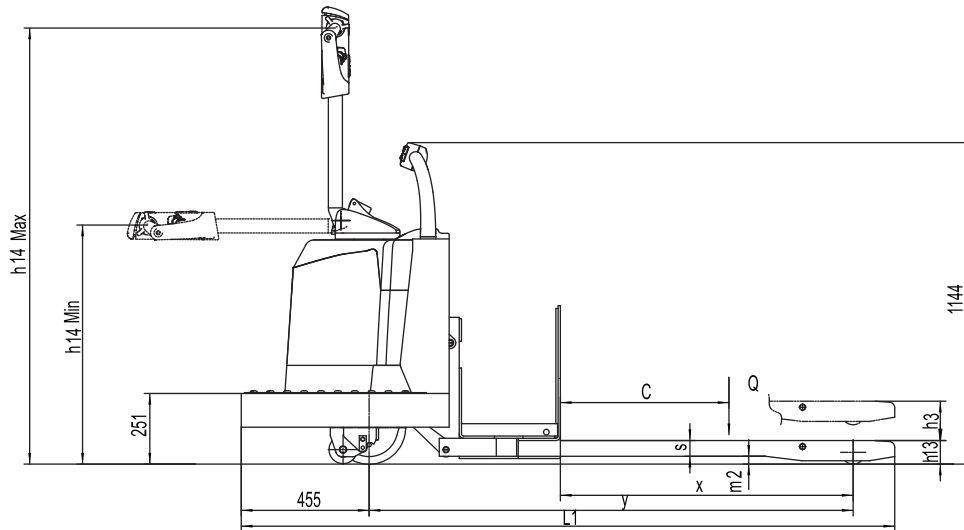

Option

Options	EPT20-30RTS/EPT20-35RTS
Fork length	○1190/2428
Fork width	○
Single load wheel	●
Driving wheel	●PU
Balance wheel	○
Battery indicator with hour meter	○
Battery indicator without hour meter	○
Battery capacity	●360Ah
Lateral change battery	○
Water auto-filling system	○
Vertical handler working	○
Fork lowered height	●82.5mm
Special backrest	○1220mm (48in)/1520mm (60in)
Note:	● standard ○ option — NA